

CUNARD DEVELOPMENT

Site Activity Update – Wednesday, October 5th, 2022

As part of Southwest's approved Construction Management Plan (May 2021), this week our Encroachment Plan will commence. The plan includes a relocated sidewalk, a bike lane closure (cyclists to share the road) and the removal of all parking on the west side of Lower Water Street across from the Cunard construction site.

This setup will be in place for the duration of the project and HRM is working with Parking Services to relocate any accessible parking in this area.

There are no planned disruptions to local services or vehicular traffic during this Halifax City approved work.

Thank you for your co-operation as we undergo construction, and we look forward to introducing an exciting new residential and retail address to Halifax.

Southwest Properties is the developer for the mixed-use residential project being constructed at 1325 Lower Water Street on the Cunard lot.

Forward any questions pertaining to site activity to Southwest Properties at urbanhalifax@southwest.ca

All community updates can be found on our company website and notices on social channels > <https://southwest.ca/developments/cunard/>

**Side walk closure will extend from in front of Cunard lot to 1475 Lower Water Street.*

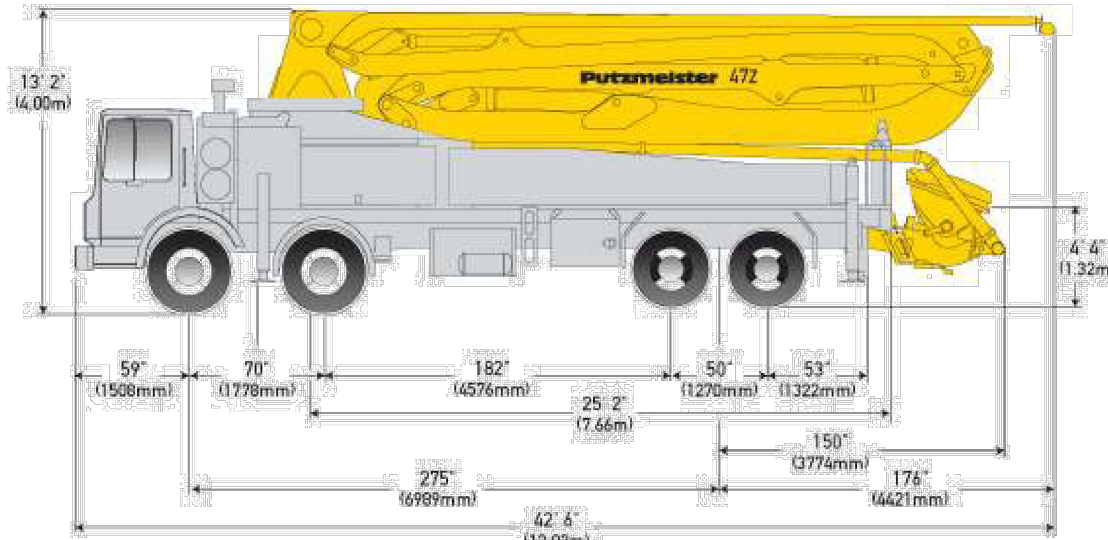

47Z

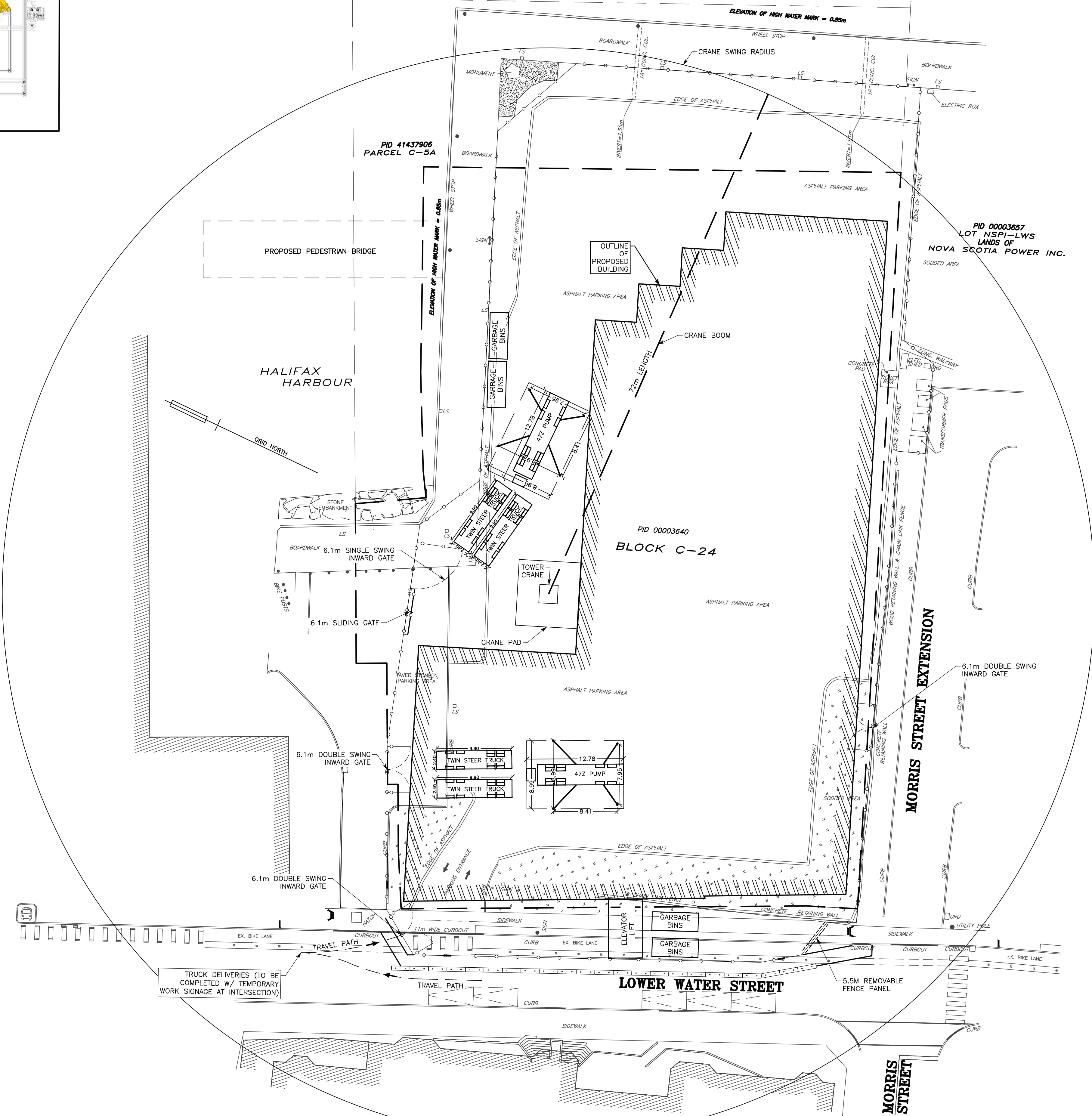

LEGEND		
EXISTING		PROPOSED
25.0	CONTOUR LINE	25.0
⊗/⊗BF	CURB STOP/GATE/BUTTERFLY VALVE	⊗/⊗BF
⊕	FIRE HYDRANT	⊕
⊠	CONCRETE THRUST BLOCK	⊠
⊠	SIAMESE CONNECTION	⊠
⊠	CATCH BASIN/PIT	⊠
—	CULVERT	—
⊠	ROCK LINING/DAM	⊠
⊠	ROCK WALL/RETAINING WALL	⊠
⊠	POWER POLE & ANCHOR/LIGHT STANDARD	⊠
⊠	TREE	⊠
⊠	STREET SIGN/PARKING METER	⊠
131.82	ELEVATION/GRADE	125.00
⊠	TEST PIT	⊠
—	DRAINAGE/SWALE FLOW DIRECTION	—
W	WATER MAIN/SERVICE	W
SAN	SANITARY MANHOLE & PIPE	SAN
STM	STORM MANHOLE & PIPE	STM
SAN/STM	COMBINED PIPE	SAN/STM
GAS	GAS LINE	GAS
FL	100YR. FLOOD LIMIT	FL
—	GUARD RAIL	—
—	UNDERGROUND CONDUIT	—
—	OVERHEAD WIRES	—
—	PROPERTY LINE/BOUNDARY	—
—	FENCE	—
—	BUILDING	—
—	TOP OF SLOPE	—
—	TOE OF SLOPE	—
—	TREELINE	—
—	LIMITS OF DISTURBANCE	—
—	TACTILE PEDESTRIAN PLATES	—
—	PROJECT SAFETY SIGNAGE	—
—	ORANGE SAWHORSE BARRICADE	—

NOTES
1. THIS PLAN IS IN METRIC.

No.	YY/MM/DD	Revision	Description	Appr'd
1	21/05/12		REVISED ENCROACHMENT	
0	21/02/10		ISSUED FOR REVIEW	



SDMM
 Servant, Dunbrack, McKenzie & MacDonald Ltd.
 NOVA SCOTIA LAND SURVEYORS & CONSULTING ENGINEERS
 36 CLAND CRESCENT
 BAYERS LAKE BUSINESS PARK
 HALIFAX, NS B3S 1G8
 PHONE: (902) 455-1537
 FAX: (902) 455-8479
 WEB: www.sdmm.ca

CUNARD BUILDING
 1325 LOWER WATER STREET
 HALIFAX, NOVA SCOTIA

CONCRETE DELIVERY SCHEMATIC

Date	February 8, 2021	Drawn	D. ANDERSON	Project No.	FILE NO. 1-1-144 (35804)
Scale	1:250	Engineer	G. MACLEAN	Plan No.	16-2482-1
Reference	Approved	Approved	G. MACLEAN	Drawing Name	
Surveyed	Sheet				R2

